

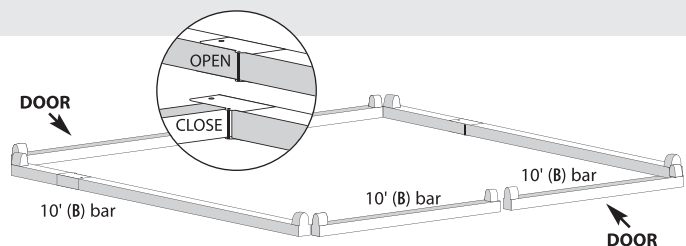

- 1** Lay out the base of your Sukkah using the **B** crossbars, with the pin facing upwards.  
Lock folded **B** crossbars in the "open" position.  
Consider door position when setting the crossbars.

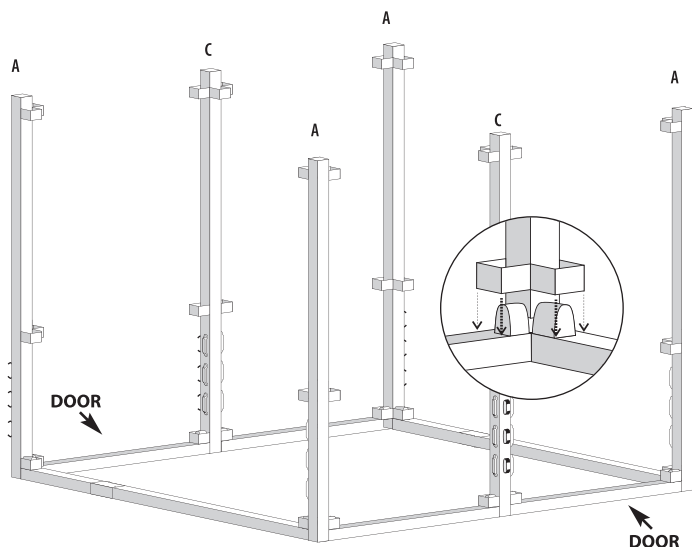

- 2** While facing the longer (door) side of the Sukkah looking in, start with the corner on your right.  
Insert the **A** upright bar onto the crossbar pins. (make sure the slots, are on the lower side of the pole.) Lift the corner and tap it lightly, making sure the fitting of the crossbars and upright bar connect tightly.  
The next **A** upright bar goes onto the corner to the left of the door. The remaining 2 **A** upright bars, go onto the back corners of the Sukkah.



- 3** Place the middle **B** crossbars into the middle fittings of the **A** & **C** bars. Then place the top crossbars directly above them. Use the mallet to tap fittings together.  
NOTE: The door area does not get a middle crossbar.

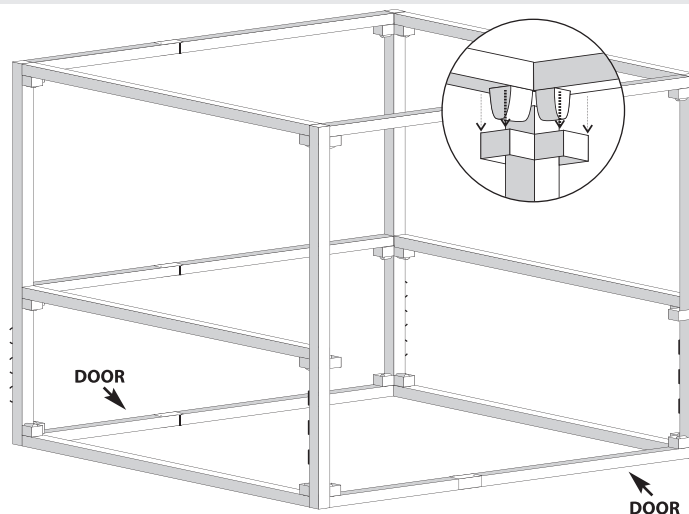

- 4** Each Sukkah has Mehadrin bands, which go around the walls of the Sukkah. The door side remains open.  
Starting with the **A** upright to the right of the door, hook a band into the top slot (*diagram 1*), and continue to the next corner, tighten the band to insure the Kashrus of the Sukkah, thread the excess band into white holder.  
Repeat the same on each wall, ending with the **A** corner to the left of the door.

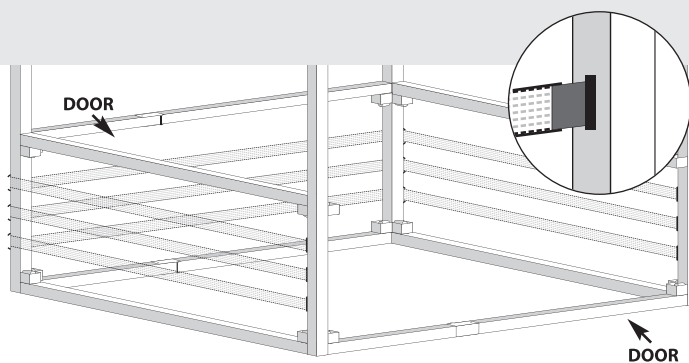

- 5** Open the nylon and find the end with the door on it. The side with the screen faces the inside. The lighter color goes on top.  
Starting with the velcro above the door (Start A). Attach the Velcro over the top of the **B** crossbars, and continue around the Sukkah, till second door (Finish A). repeat with second nylon (from start B to Finish B).  
Tie the straps at the **A** corner uprights, and attach Velcro where the two ends meet.  
Attach all the middle & bottom Velcro.

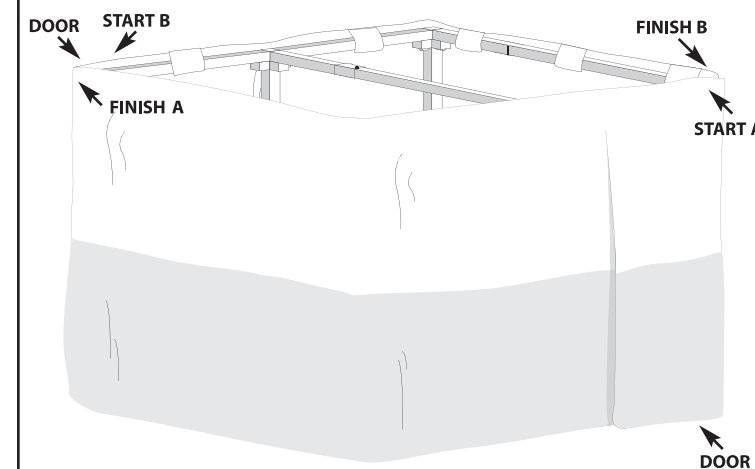

- 6** Place bamboo sticks (not included) over the top crossbars using the bamboo holders. The bamboo sticks should be evenly spaced from each other and from the walls of the Sukkah.  
*\*Necessary for the kashrus of the schach*

