

**1** **PANEL TO PANEL ASSEMBLY**  
**NOTE:** All panels and corner sections work on a Male/Female assembly system. So using two Male sides or two Female sides (of matching panels or corner sections) will not work.  
**Don't leave Window or Painted Panels for last, since they can't be turned upside down.**  
 Position panels at a 45° angle then insert male side of panel (1) into female side of panel (2), as shown in diagram. Swing panels into place. (see arrow)  
 The door panel is the same size as the wall panels and may be substituted for any 4ft panels throughout your sukkah.  
 If panels don't match up, turn one panel upside-down. (there is no top or bottom to the panels)

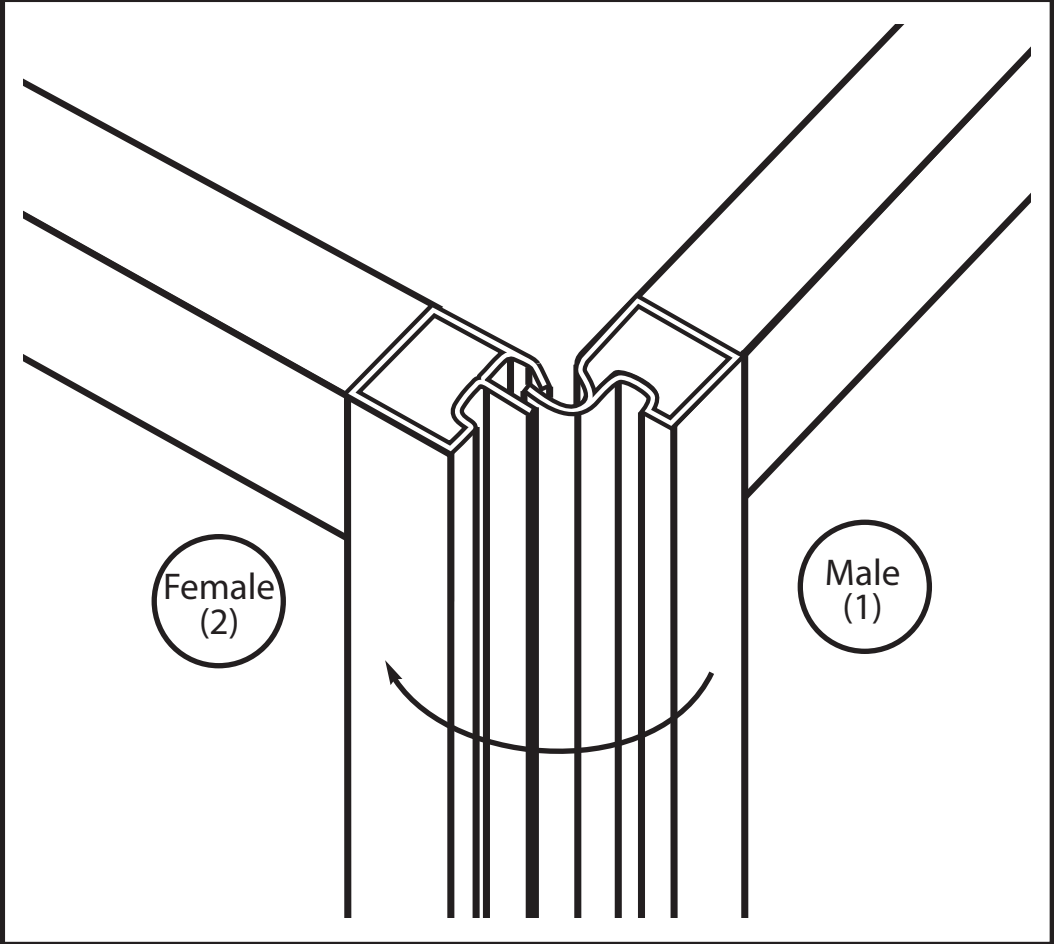

**2** **PANEL LOCK INSTALLATION**  
 After each panel to panel connection is made, Use clamps (see diagram) to fasten panel to each other. Clamps can be placed anywhere along the panels, and can be placed either inside or outside.  
 For the 4th corner, use 2 clamps. Fasten from the corner frame to each wall panel.  
 For extra security you can place clamps on ALL corners.

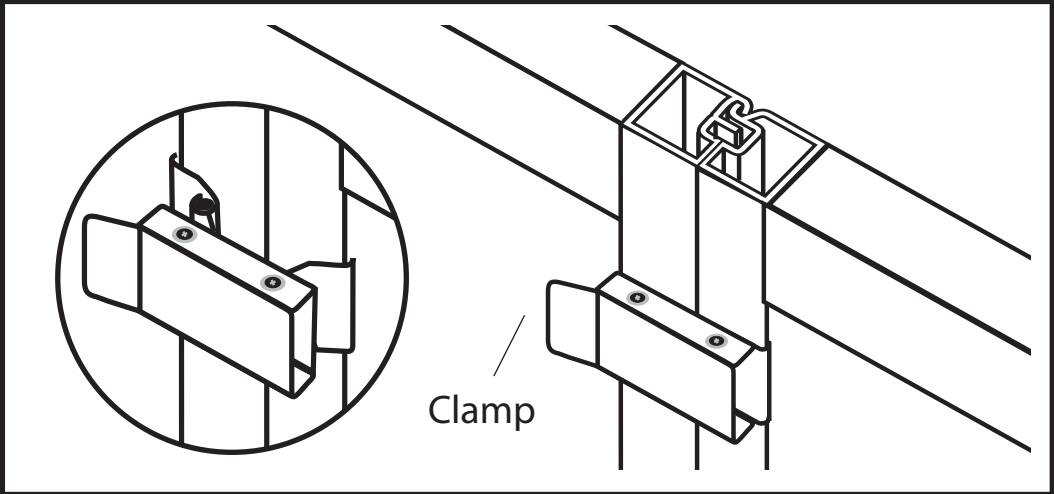

**3** **CORNER ASSEMBLY**  
 Hook male side of corner section into female side of panel then swing in the direction of arrow shown in diagram.  
**NOTE:** The next panel is assembled to the male side of the corner in a similar fashion.  
**Three Short corners should be left for last.**

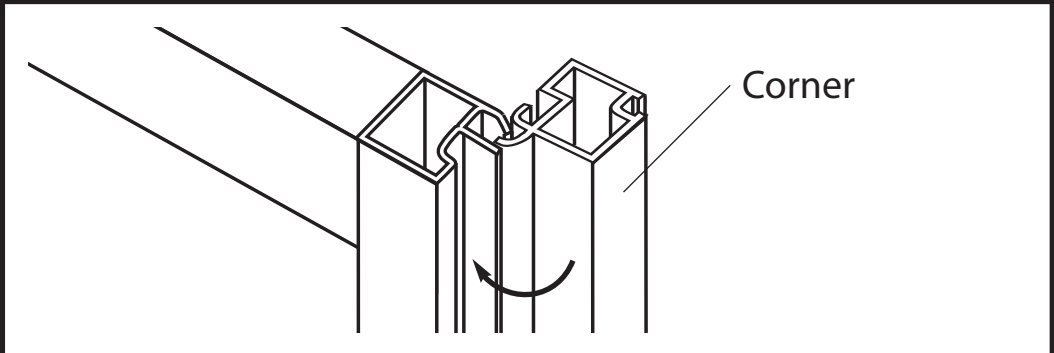

**4 ASSEMBLY OF LAST CORNER**  
 (This step is for 4-sided sukkahs only)  
 On a 4-sided Sukkah one corner must be left for last. This last corner will use the three corner sections to join the last two panels together. These two short corner sections are to be slid into place, (not hooked) starting at the top of the last corner and sliding down.  
**NOTE:** You may need a step-ladder to see that you are sliding the corner sections in properly.

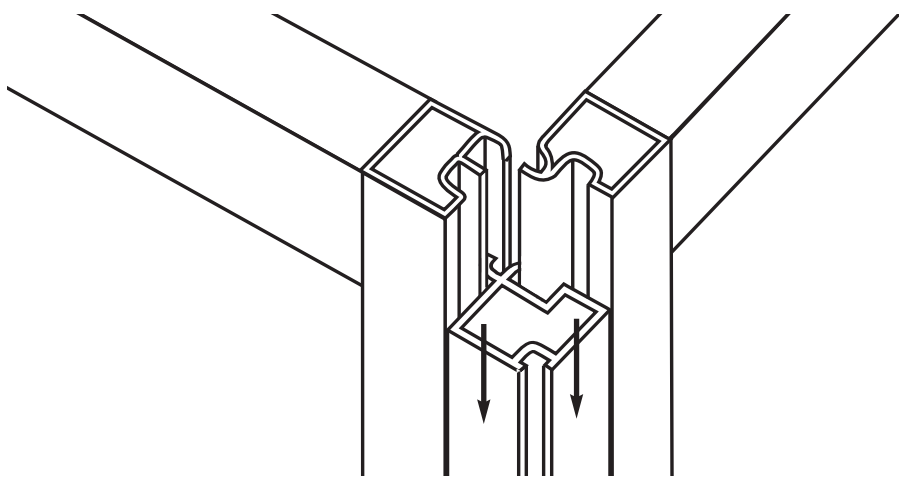

**5 TOP OF SUKKAH WOOD BEAM ASSEMBLY**  
 Place 2" x 3" lumber beams on the top of the Sukkah, as shown in the diagram.  
**NOW YOU CAN PUT ON THE SCHACH AND YOUR SUKKAH IS COMPLETE.**

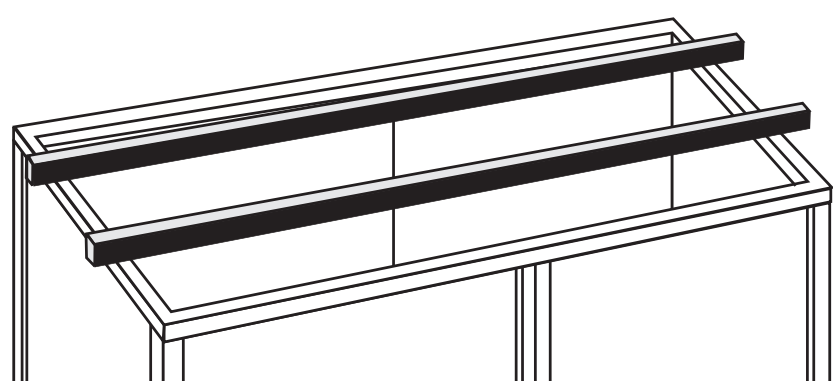

**6 FOR LARGER SUKKAHS**  
 Special top "S" clamps have been provided to give the side walls greater rigidity and stability.  
 Slide wood bars into position as shown in diagram.

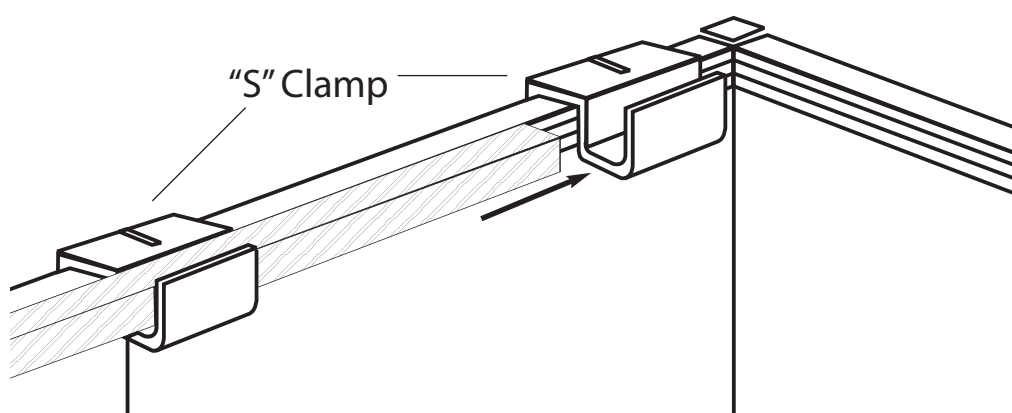

**7 FOR SUKKAHS WITH ONLY THREE WALLS**  
 Attach the two (2) Wall Support Brackets to wall with screws. This can be a permanent installation.  
 Slide Sukkah panel into bracket as shown in diagram.

