



## BEFORE YOU BEGIN

Please read all the instructions before assembly.

Think about where your Sukkah will be placed. It needs to stand on fairly level ground. Please keep in mind on which side you want the door to be. Unless you ordered a special Sukkah the door will be on the right of a longer side of the Sukkah.

Unpack your Sukkah from the box and open all the packages. Take the time to familiarize yourself with all the parts. Please check the parts list on back page to make sure you are not missing anything.

If you think something is missing, please call our customer service department at **1-800-227-SUKA**

### Assembling your Snap Sukkah System:

When assembling the frame of your Snap-Sukkah, we recommend that steps 1-3 be completed without leaving the frame partially standing for an extended amount of time. Failure to do so might cause damage to some of the pieces.

## WHEN YOU FINISH

When using mat or bamboo Schach, (not included,) lay it perpendicular to the wooden supports. You may need extra supports to hold the weight of the bamboo.

Do not hang any decorations from mats. They are not designed to hold any weight. Decorations can be hung from the wooden supports or from bamboo rod-type Schach.

**NOTE:** If your Sukkah is placed in a large open area or is subject to strong winds, secure it using bungee cords (or other types of fastening material i.e. string) and tightening it to a secure object. This will help prevent it from shifting or blowing over.

**IN THE EVENT OF WIND, PLEASE REMOVE NYLON,  
TO REDUCE THE RISK OF DAMAGE TO SUKKAH**

## PART LIST

OPEN ALL PACKAGES BEFORE COUNTING

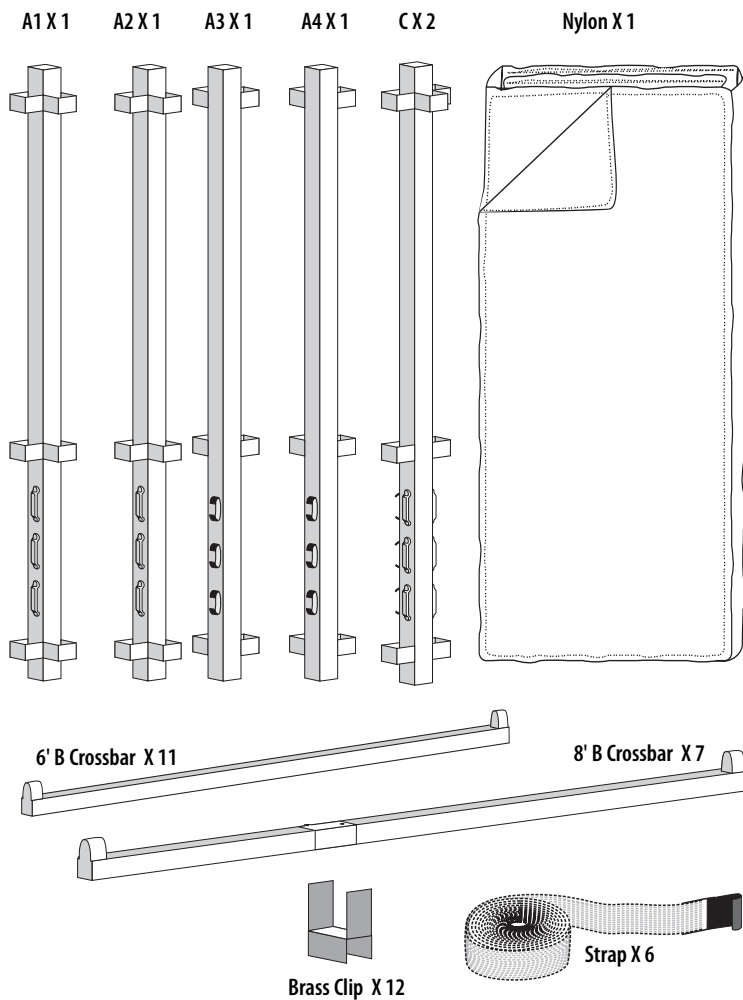

**THE SUKKAH CENTER**  
3720 14th Avenue • Brooklyn, NY 11218  
718-436-6333 • www.sukkah.com

© 2004 Sukkah Center • Brooklyn NY 11218



# SNAP SUKKAH

8'x12'

Actual size  
95"x143"

## ASSEMBLY INSTRUCTIONS

**Your sukkah has  
been designed for  
E-Z installation**

**Thank you for purchasing our Snap Sukkah System.**  
We hope you will enjoy many years of pleasant & enjoyable holidays with your sukkah. Your feedback is important to us. Please call us at

**1-800-227-SUKA**  
**www.sukkah.com**



- 1** Lay out the base of your Sukkah using the **B** crossbars with the pin facing upwards.  
Lock folded **B** crossbars in the "open" position. Consider door position when setting the crossbars.

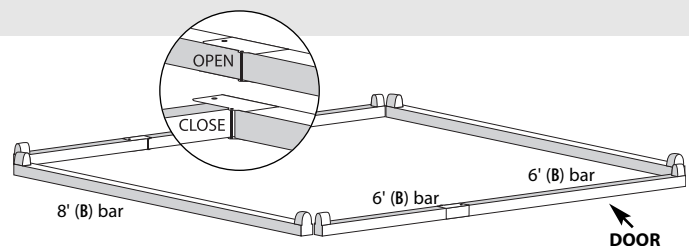

- 2** While facing the longer (door) side of the Sukkah looking in, Start with the corner on your right. Insert the **A1** upright bar onto the crossbar pins. (make sure the arrow is facing up, and the closed loops, are facing the back of the Sukkah.)

Lift the corner and tap it lightly, making sure the fitting of the crossbars and upright bar connect tightly.

The **A2** upright bar goes onto the corner to the left of the door. The **A3** & **A4** upright bars, go onto the back corners of the Sukkah. The **C** uprights go at the center.

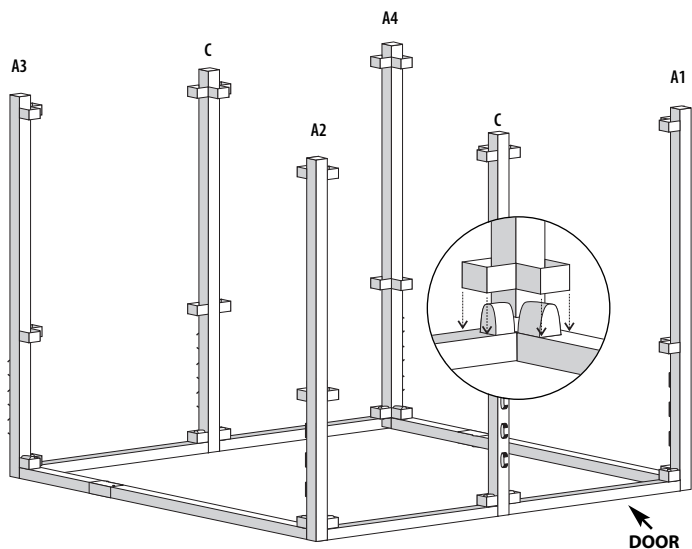

- 3** Place the middle **B** crossbars into the middle fittings of the **A** & **C** bars. Then place the top crossbars directly above them. Use the mallet to tap fittings together.  
NOTE: The door area does not get a middle crossbar.

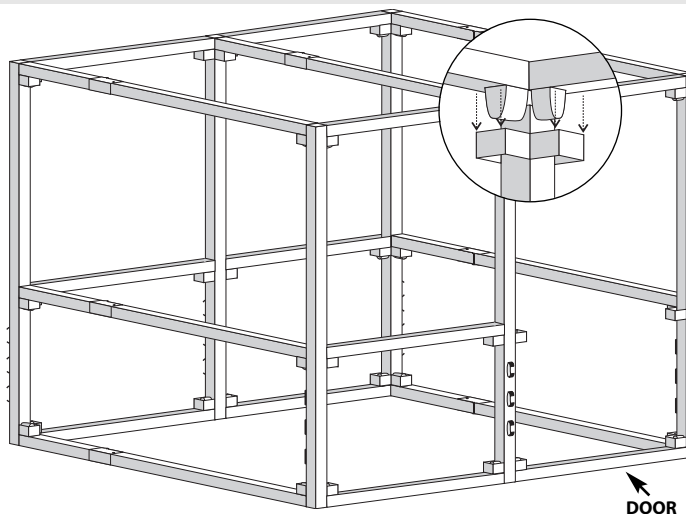

- 4** Each Sukkah has 3 mehadrin bands (2 sets) which go around 3 walls of the Sukkah. The door wall remains open. Starting with the **A1** upright to the right of the door, hook a band into the top loop (diagram 1), and continue counter clockwise around the Sukkah. Thread the bands through the guides on each upright, (diagram 2) ending with the back **C** upright. Fasten the band properly.\*

Continue with a second band, starting with the **C** upright of the back wall, ending at the front **A2** upright.

Repeat for remaining bands.

*\*To insure the Kashrus of the Sukkah.*

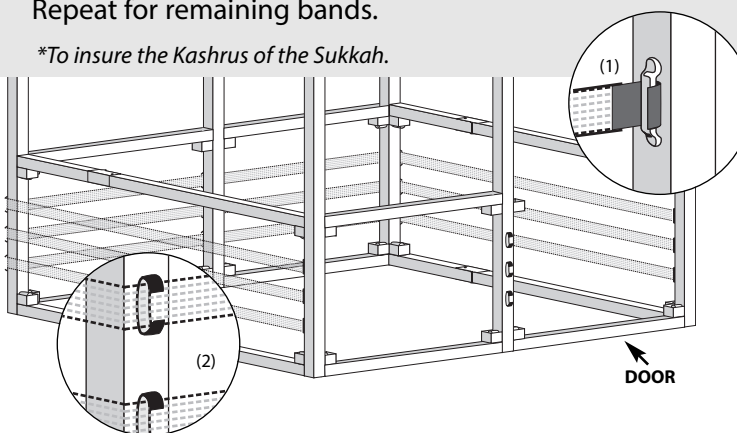

- 5** Open the nylon and find the end with the door on it. The side with the screen faces the inside. The lighter color goes on top.

Starting with the velcro above the door. Attach the Velcro over the top of the **B** crossbars, and continue all the way around the Sukkah, till both ends of the nylon meet.

Tie the straps from both ends to the **A1** corner upright, and attach Velcro where the two ends meet. Attach all the middle & bottom Velcro.

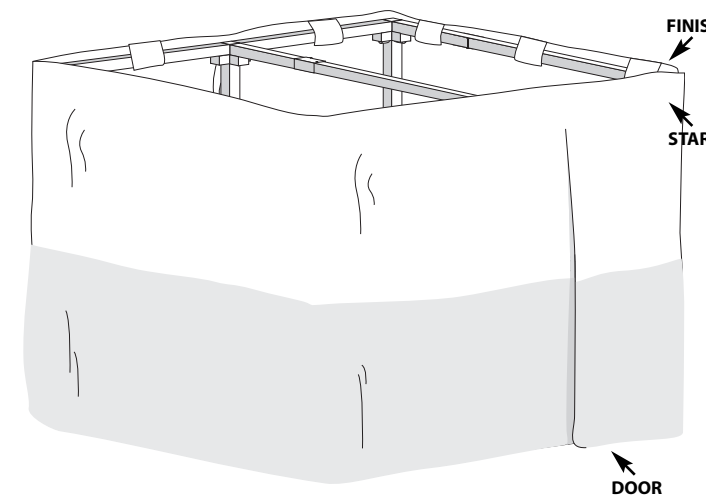

- 6** Place wood\* crossbeams (1"x2", not included) over the top crossbars using the brass clips. The wood beams should be evenly spaced from each other and from the walls of the Sukkah.

*\*Necessary for the kashrus of the schach*

